

# Spinner II centrifuges: efficiency and capacity for any mining equipment application

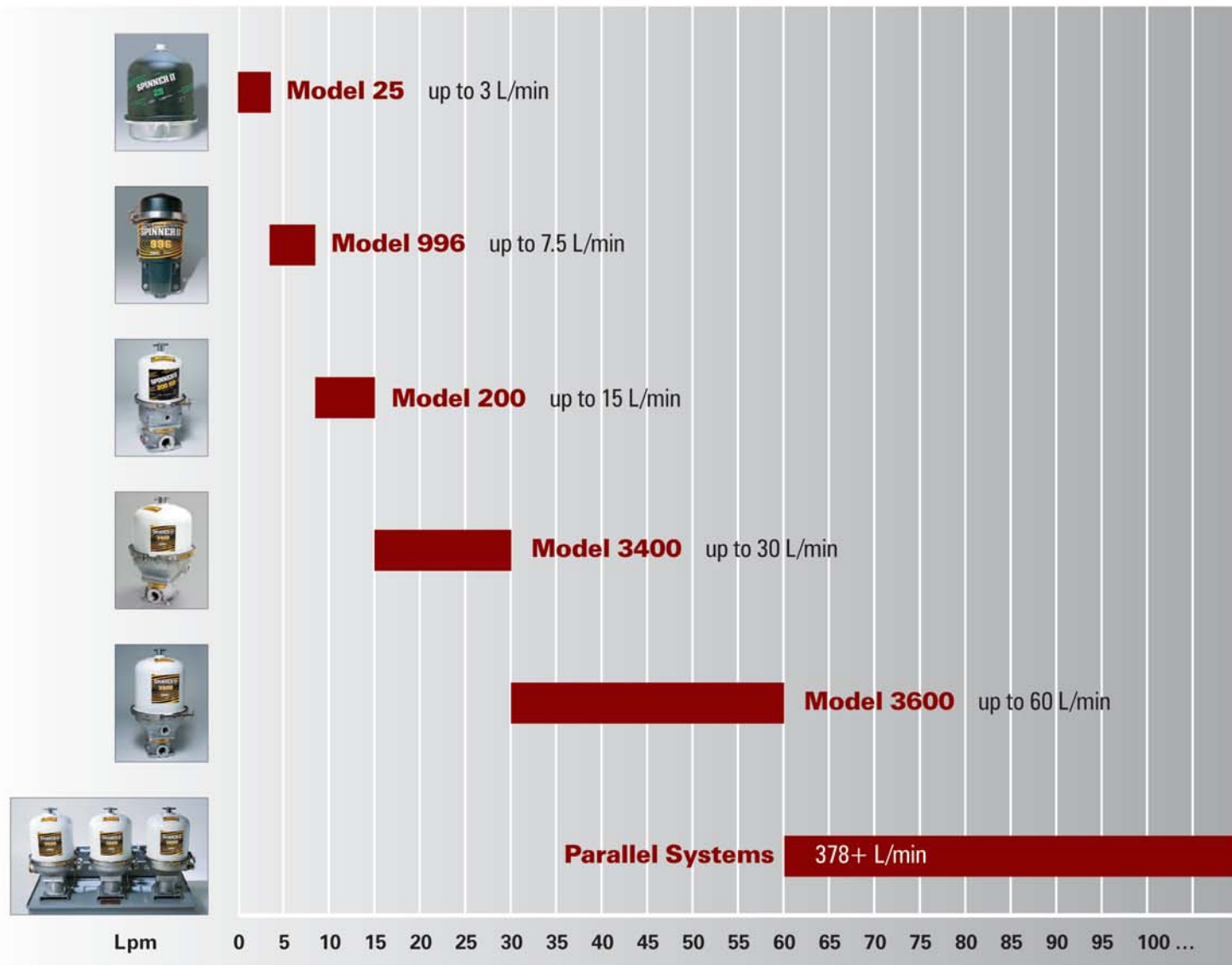

## Proven World-Class Performance

For over 30 years, Spinner II centrifuges have provided exceptional fluid-cleaning performance, with more than 650,000 units in operation worldwide. They have been installed as OEM first fit for more than 50 engine manufacturers — including Caterpillar, Waukesha, White Superior, EMD, Alco, General Electric, Detroit Diesel, Clark Bros., Ingersoll-Rand, Cooper-Bessemer, Cummins, MTU and many others.

Spinner II centrifuges can be specified on new equipment or retrofitted to existing machinery. Every unit is backed by responsive engineering and technical support.

To find out how Spinner II Xtreme Cleaning makes your operation more productive and cost-effective, contact your Spinner II Products representative.

©Spinner II and Xtreme Cleaning are marks of T.F. Hudgins, Incorporated.  
™ Grid Switch is a mark of T.F. Hudgins, Incorporated.  
©2007 T.F. Hudgins, Incorporated. All rights reserved.  
All other marks are properties of their respective owners.

# SPINNER II<sup>®</sup> PRODUCTS

[www.SpinnerII.com.au](http://www.SpinnerII.com.au)



**Oil Conditioning Systems NZ Ltd**  
PO Box 132-007 Sylvia Park, Auckland 1644  
16 Aranui Rd (Apex Duo) Mt Wellington  
Auckland 1060 Ph: (09) 570 2944  
Fax: (09) 570 2942 Mob: 0274 485 942  
Email: [info@oilconditioningsystems.co.nz](mailto:info@oilconditioningsystems.co.nz)  
Web: [www.oilconditioningsystems.co.nz](http://www.oilconditioningsystems.co.nz)



## Spinner II<sup>®</sup> Oil Cleaning Centrifuges

# Xtreme Cleaning<sup>™</sup>

for Oils and Lubricants

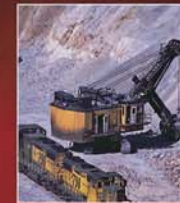

Reduce Unscheduled Stoppages

Extend Plant and Machinery Service Life

Decrease Maintenance Costs

# SPINNER II<sup>®</sup> PRODUCTS

# Xtreme Cleaning reduces unscheduled stoppages

## Mobile Plants, Mills, Cone Crushers, Shovels, Pumps, Compressors and More

*Oil is the lifeblood of mechanical processes. Keep it ultra-clean and your machines will run longer, last longer and cost less to operate. That's the essence of Xtreme Cleaning, the performance you get only with Spinner II centrifuges. And that's the reason why Spinner II centrifuges are used extensively in mining operations worldwide.*

Spinner II centrifuges are highly efficient, self-contained, oil-cleaning units for bypass and off-line filtration of engine lubricants, transmission oil, gear oil and hydraulic oil.

Using the power of centrifugal force, they remove both large contaminants and ultra-fine particles as small as one-tenth of a micron. In a broad range of applications, Spinner II centrifuges are proven to reduce critical component wear up to 50%\*. They also meet the challenge of new, low-emissions engines by providing the efficiency to control increased soot loads.

### High Efficiency

Spinner II centrifuges feature a patented rotor design with enhanced flow dynamics. Biased flow channels in the rotor cover act as "centrifugal pumps," forcing fluid away from the axis to maximize liquid/solid separation.



Patented flow channels

### How Xtreme Cleaning Reduces Unscheduled Stoppages

#### Protects Plant and Machinery

- Reduces wear up to 50%
- Increases component life
- Helps reduce frequency of maintenance and repair

#### Extends Operating Intervals

- Keeps fluids and additives effective longer
- Prolongs full-flow filter life
- Centrifuge requires minimal service

#### Requires Minimal Maintenance

- Permanent, cleanable and reusable
- No media or filter elements to replace

### How Spinner II Centrifuges Operate

Spinner II centrifuges are typically self-powered (pump-assisted units are also available). They create fluid pressure sufficient to generate centrifugal force 2,000 times greater than gravity. This force extracts solid contaminants from the fluid stream and deposits them in the cleanable rotor as a dense, solid cake.

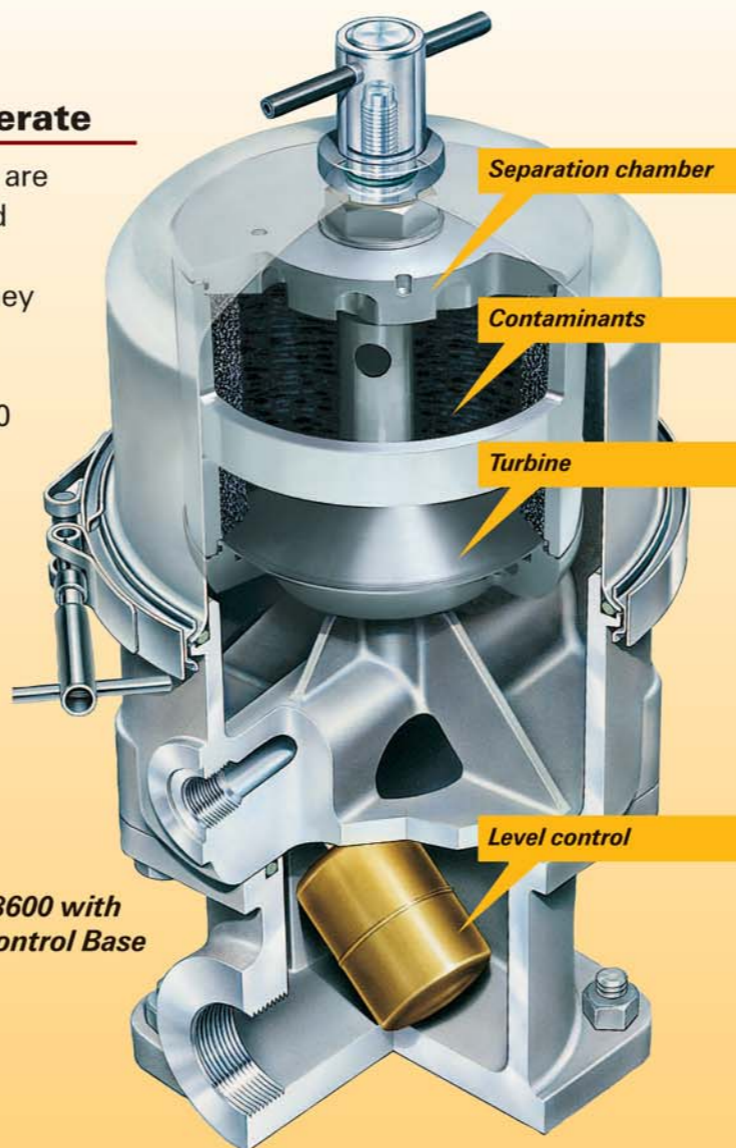

Model 3600 with Level Control Base

### Flow Path

Fluid passes through a spinning rotor where centrifugal force 2,000 times greater than gravity separates contaminants from the fluid.

Clean fluid returns to the sump/reservoir from the level control base.

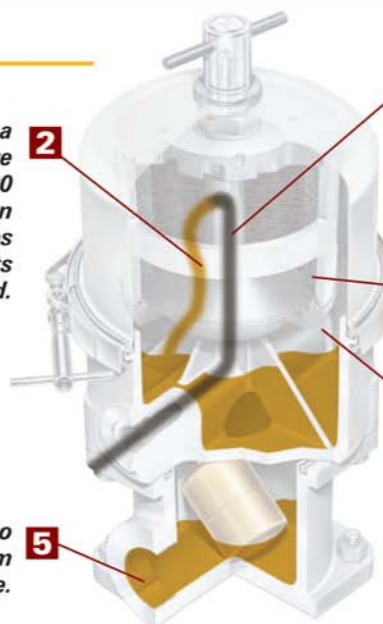

1 Dirty fluid flows up through a hollow spindle into a separation chamber.

3 Contaminants accumulate on the rotor surface as a solid cake.

4 Clean fluid exits from tangentially-opposed nozzles, powering the centrifuge up to 7,000 rpm.

### Operational Advantages

- Maintains constant cleaning efficiency
- No channeling, plugging or fouling
- Simple, convenient installation
- No replacement elements
- Contaminant access for engine troubleshooting
- Enhances long-term preventive maintenance

### Low Maintenance, Easy to Service

Maintenance intervals for Spinner II centrifuges vary according to your specific operating conditions and service hours. However, all models are designed with large capacities to allow extended hours of service.

For routine maintenance, simply remove the rotor cover and empty the dry, compacted contaminants. There are no expensive filter elements to replace and nothing to drain, crush or haul away.



**Spinner II Grid Switch Wear Detectors.** These optional devices can be installed in-line to monitor the presence of metal particles and provide advanced warning of excessive wear conditions.

### Would you want this in your engine?

Clean (top) and dirty (inset) rotors from a Model 3600 centrifuge show actual contaminants removed in one lube oil service interval.



\*Test reports available