

Spinner II® Model 3600 Centrifuge



Spinner II centrifuges provide highly efficient, ultra-fine fluid cleaning to protect heavy-duty engines and other machinery. They are proven effective in cleaning lube oil, as well as transmission, hydraulic, metalworking and other fluids.



Operating at speeds up to 4,000 rpm, Spinner II centrifuges remove both large particles and contaminants as small as one-tenth of a micron. Units are typically self-powered (pump-assisted configurations also available), using fluid pressure to generate centrifugal force 2,000 times greater than gravity. This force extracts solid contaminants from the fluid stream and stores them as a dense, solid cake in a cleanable rotor.

How SPINNER II CUTS OPERATING COSTS

Protects machinery:

- Reduces wear (call for test reports on 50% reduction in engine wear)
- Handles **increased soot loads** produced by new, reduced-emissions engines
- Enables fluid additives to remain effective longer
- Reduces frequency of maintenance and repair
- Extends machinery life

Extends service intervals:

- Extends fluid life, reducing material and labor expenses
- Extends full-flow filter life, reducing disposal costs and liabilities
- Lengthens service intervals, reducing downtime and increasing productivity
- Frees maintenance personnel for other work

Cleanable and reusable:

- No filter or elements to replace
- Better for the environment
- Easy-to-clean, three-piece rotor

Specifications

PRIMARY APPLICATIONS: heavy-duty diesel and gas engines, pumps, generator sets and specialized equipment in a variety of industrial, oil and gas, marine, construction and mining industries

SOLID PARTICLE REMOVAL: down to one-tenth of a micron

FLOW CAPACITY: 960 gallons per hour

CENTRIFUGE POWER SOURCE: normal system pressure or separate pump motor

SOLIDS HOLDING CAPACITY: 6,000 cubic centimeters

SERVICE PROCEDURE: remove and clean rotor by hand; no special tools required

High-Efficiency Rotor

Model 3600 centrifuges feature a patented rotor design with superior flow dynamics. Biased flow channels in the rotor cover act as “centrifugal pumps,” forcing fluid away from the axis. This enhances liquid/solid separation.

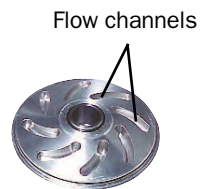

Low Maintenance, Easy To Clean

The Model 3600 is a large-capacity unit which remains in service many times longer than an ordinary media filter. Specific centrifuge maintenance intervals will vary, based on operating conditions and service hours.

Like all Spinner II centrifuges, the Model 3600 is durable and requires little maintenance. There are no costly filter elements to replace and no used elements for disposal. To service the centrifuge, simply remove the cover and empty the dry, compacted contaminants from the reusable rotor* Model 3600 centrifuges feature quick-clean, three-piece rotors, making service even easier.

**For complete instructions, see Service and Installation Bulletin No. 73360.*



Quick-clean, three-piece rotors allow faster, easier service.

Spinner II® Model 3600 Centrifuge

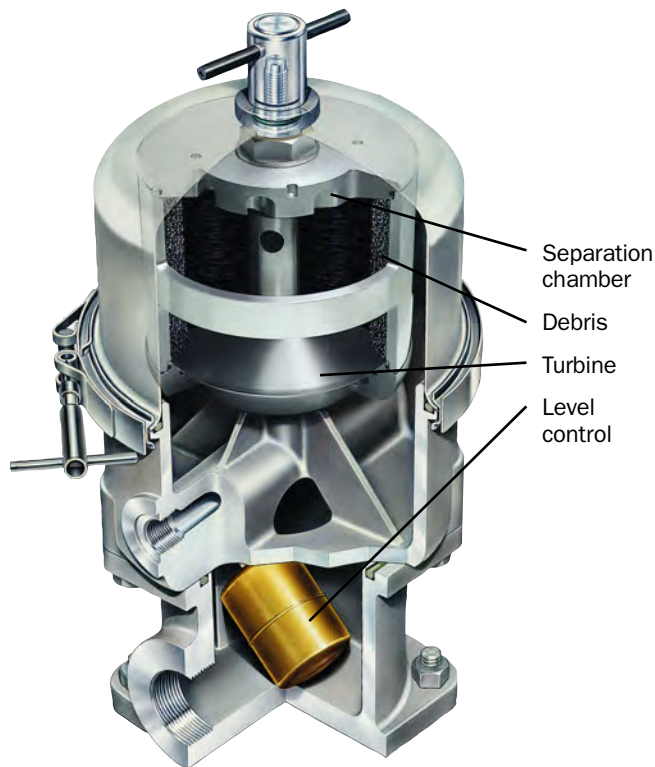

Operation

- 1 Dirty fluid enters the separation chamber under normal pressure, flowing up through a hollow spindle
- 2 Fluid passes through a spinning rotor where centrifugal force 2,000 times greater than gravity separates contaminants from the fluid
- 3 Contaminants accumulate on the rotor surface as a solid cake
- 4 Clean fluid exits from opposing, twin nozzles that power the centrifuge up to 4,000 rpm
- 5 Clean fluid returns to the sump/reservoir from the level control base

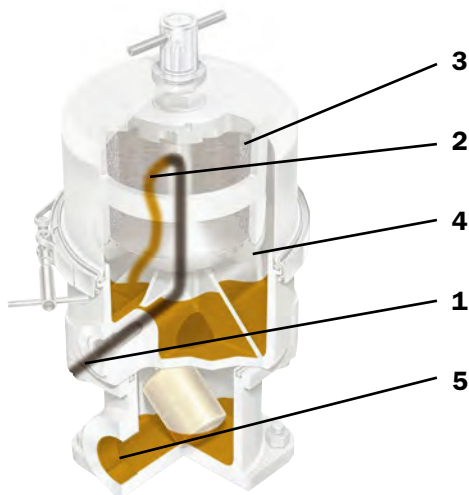

Spinner II CS systems combine a centrifuge and full-flow, cleanable screen.

Custom-Engineered Systems

Spinner II Products will engineer systems to satisfy specific needs, including:

- **Spinner II CS Systems.** Combines a Spinner II centrifuge with a full-flow, stainless steel cleanable screen for a completely cleanable, reusable fluid cleaning solution.
- **Spinner II CX Systems.** Multi-centrifuge packages operating in parallel for high-volume applications.
- **Spinner II CP Systems.** Combination centrifuge/pump units for constant fluid cleaning.

SPINNER II® PRODUCTS



Oil Conditioning Systems NZ Ltd
PO Box 132-007 Sylvia Park, Auckland 1644
16 Aranui Rd (Apex Duo) Mt Wellington
Auckland 1060 Ph: (09) 570 2944
Fax: (09) 570 2942 Mob: 0274 485 942
Email: info@oilconditioningsystems.co.nz
Web: www.oilconditioningsystems.co.nz



Made in England by Mann+Hummel (UK) Ltd.
©Spinner II is a registered trademark of T.F. Hudgins, Incorporated.
Patented worldwide.
© 2004 T.F. Hudgins, Incorporated. All rights reserved.
Litho in U.S.A. Bulletin No. 73384/1M/7-04