

SPINNER II®

OIL CLEANING CENTRIFUGE

Oil Conditioning Systems NZ Ltd

PO Box 132-007 Sylvia Park, Auckland 1644

16 Aranui Rd (Apex Duo) Mt Wellington

Auckland 1060 Ph: (09) 570 2944

Fax: (09) 570 2942 Mob: 0274 485 942

Email: info@oilconditioningsystems.co.nz

Web: www.oilconditioningsystems.co.nz



Model 200 HD 4 gpm at 60 psig
2,000 cc Dirt Capacity

Installation Instructions

Parts List

Service Instructions



Oil Supply to Centrifuge

Oil supply should, in general, be taken from the highest pressure, hottest source available on the dirty side of the full-flow oil filter. A ½-in. pipe or #8 hose supply line should be used with a full-opening ball valve installed at the centrifuge oil inlet so that the unit can be isolated for service without shutting down the engine. Preferred pressure is 60 to 80 psig but the Spinner II centrifuge will operate efficiently at 35 to 90 psig. Below 35 psig, an internal idle cut-out valve will close to prevent low oil pressure during low-speed operation.

Clean Oil Return to Sump

Using Level Control Base (LCB) — PREFERRED

The air-operated control in Part No. 71602 LCB permits the Spinner II centrifuge to be installed on the frame rail, base plate or deck in any convenient location near the engine, above or below the sump oil level. First, mount the Spinner II unit with Part No. 70916 seal to the LCB using the four cap screws and washers supplied and install the Part No. 71050 air regulator into the air cartridge 71603. Then securely mount the complete assembly using four ½-in. bolts through the holes in the LCB base. See the parts list on the next page.

The clean oil drain line to the sump should be 1-in. minimum diameter, *unrestricted* hose or pipe to a 1-in. connection located above oil level if possible — alternate oil fill openings or drilled-and-tapped holes in crankcase doors are possibilities. A below-oil-level return drain requires that a 1-in. swing check valve be located at the LCB oil discharge to prevent back-flow when the centrifuge is being serviced. Only low-pressure-drop swing check valves are permitted in the drain line — **shut-off valves must never be used.**

Control Air Supply. The control in the LCB maintains the proper oil level for maximum centrifuge speed and efficiency. Compressed air to operate the LCB may be obtained from any 2 to 125 psi unregulated air source, as 0.02SCFM is minimal. Any inlet pressure exceeding 125 psi must be regulated using P/N 71050. This regulator should be installed as shown, with a ¼-in. air line connected to it using liquid sealant on threaded connections. In the absence of compressed air, it may be possible to use bleed air from the engine turbocharger or air from a positive displacement scavenging blower. This requires modifying the LCB for low-pressure operation. Remove regulator P/N 71050 and connect air supply directly into cartridge P/N 71603. This revised P/N 71603 is marked with wide band on hex. Use of 71246 Pre-Filter is recommended.

Using Gravity Drain — Engine Mounted Only

For a gravity drain without the LCB, the Spinner II centrifuge must be close-coupled to the sump with an unrestricted 2-in. I.D. drain which must return above the normal sump oil level. The drain line must be sloped downward from the centrifuge outlet and be free of sharp bends or traps. A crankcase door can be modified to provide a suitable drain opening and mounting point. Be sure the sump side of the drain opening is clear and that the drain oil does not impinge on moving parts of the engine. Mounting elbows are available from Spinner II Products.

Mechanical Considerations

Spinner II centrifuges are high-speed devices and should be securely mounted to prevent excessive vibration. Operation up to 10 degrees from vertical is permitted.

Detailed Information Available

For optimum performance of your centrifuge, specific installation drawings for almost any engine can be requested from your distributor.

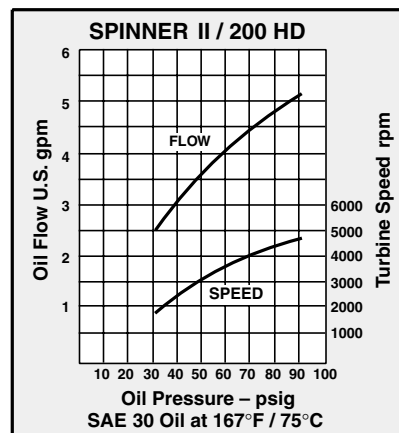
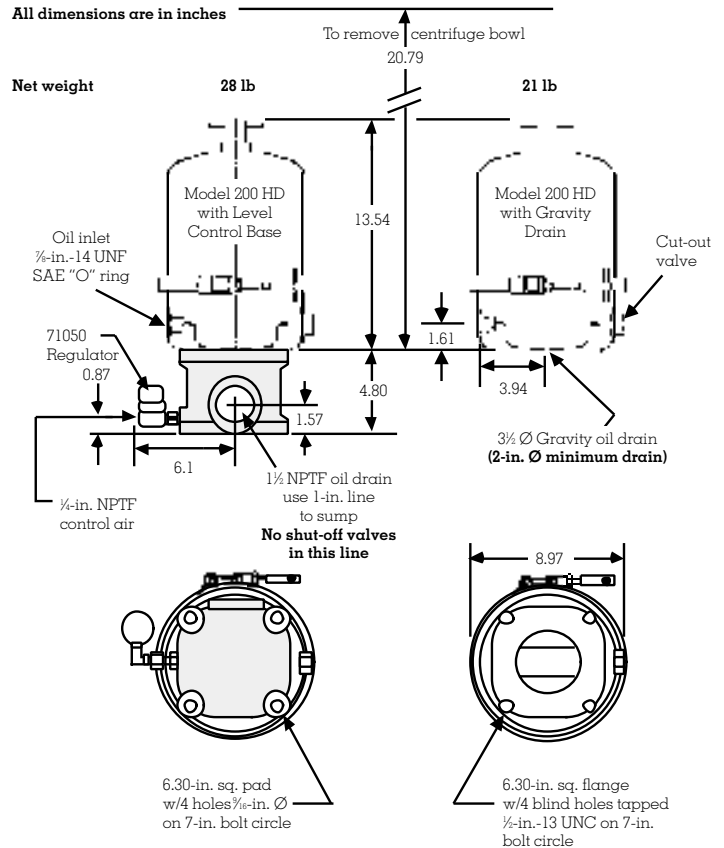

Model 200 HD Parts List

Description

Part number

Only items shown with part numbers are available.

Bold denotes assembly

Centrifuge, Spinner II/200 HD with 71602 level control base...	71404
Centrifuge, Spinner II/200 HD only	71403
Cover assembly (no clamp)	71510
Nut assembly-cover	71511
(includes pin, collar and seal)	
Seal-cover nut	70868
Clamp with tee handle-cover to base	71514
Tee bolt and handle-clamp	71515
Centrifuge turbine assembly	70870
Nut-centrifuge bowl	70871
Bowl-centrifuge (part of 70870)*	
Insert-centrifuge bowl (package of 25)	70974
Baffle/screen-centrifuge	70873
Seal-centrifuge bowl (Viton®)	70874
Bearing tube assembly-centrifuge	70976
Turbine (part of 70870)*	
Nozzle turbine (2 required)	70975
Tool, centrifuge disassembly (not shown)	70950
Base assembly with spindle (no clamp)	71516
Seal-base to cover (Viton)	70878
Seal-idle cut-out valve	70881
Kit-repair, idle cut-out valve	70880
Gasket-base flange (gravity drain only)	71959
Fitting-straight inlet 1/2-in. SAE x 1/2-in. F pipe (not shown)	70955
Fitting-straight inlet 1/2-in. SAE x #8 hose (not shown)	70953
Base-level control with hardware	71602
Seal-level control base (included) (Viton)	70916
Bolts 1/2-in.-13 UNC x 1 1/4-in. and washers (4 each included)	
Cock-safety drain	71057
Regulator-air for 71602	71050
Kit, repair-control float assembly (not shown)	71609
Cartridge-air valve, industrial	71603

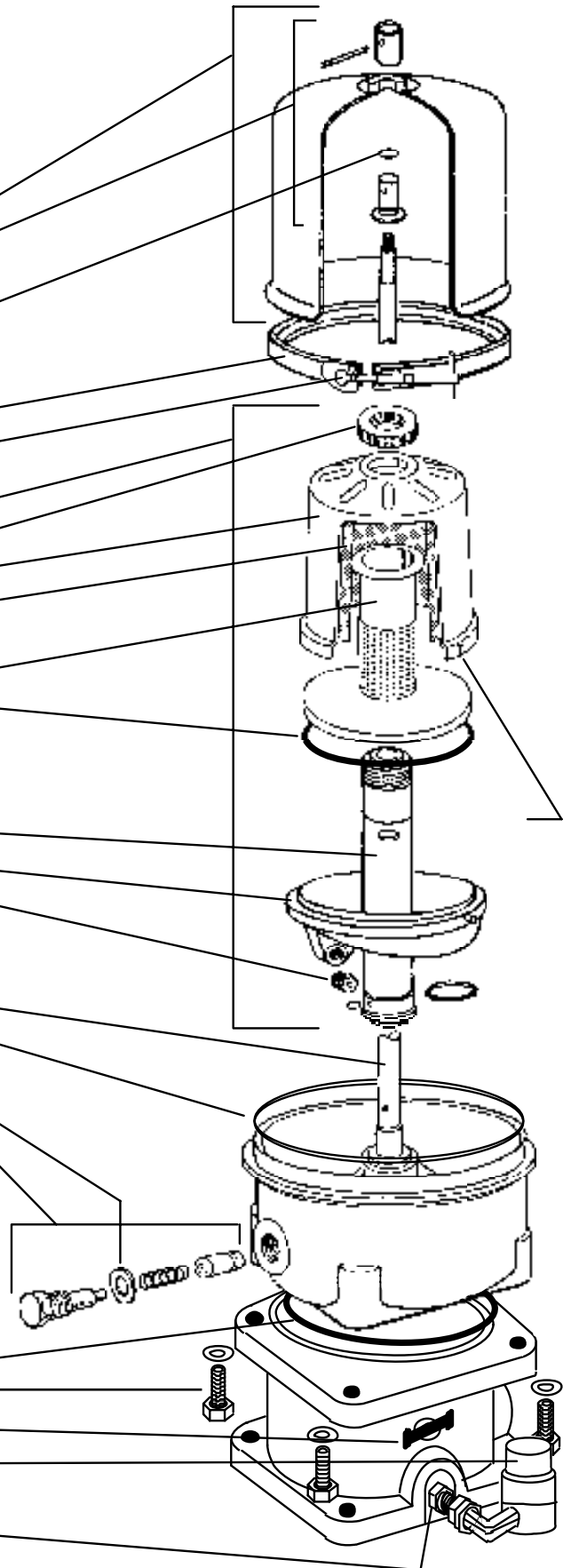

*Individually match balanced to bowl — not interchangeable.

1. Shut off control air. Shut off oil supply or stop engine and allow centrifuge turbine assembly to come to a complete stop. **CAUTION:** Open safety drain cock on side of the Level Control Base (if equipped) and be certain that the unit is not pressurized. If cock is under pressure, locate the source and remove before proceeding. *Check especially for unauthorized shut-off valves in the oil drain line to the sump and remove if found.*
2. Remove cover clamp, unscrew cover nut and remove cover assembly.
3. Partially withdraw centrifuge turbine assembly from the base assembly and allow oil to drain from nozzles before removing completely. Carefully separate centrifuge bowl from turbine. (An optional tool, Part No. 70950, is available to facilitate the disassembly process.) *Do not strike the nut or bushings with or against a hard surface or damage will result.* Remove baffle/screen.
4. Carefully remove the dirt cake from the centrifuge bowl using a wooden spatula or other non-damaging tool. Wipe out bowl with solvent and wash baffle/screen and other parts.
5. Clean turbine and examine top and bottom bearings for excessive wear. Replace bearing tube assembly (Part No. 70876 or 70976), if diameters exceed 0.593-in. (15.06 mm) top or 0.854-in. (21.69 mm) bottom. Check turbine nozzles to ensure free passage of oil. Inspect centrifuge bowl seal and replace if damaged. The seal is Viton and can be reused several times.
6. Seat baffle/screen in turbine, replace bowl (using the optional Part No. 70974 insert liner if desired) and reassemble, tightening the bowl nut securely *using finger pressure only*. Make sure that the bowl seal is uniformly seated all the way around. **Important:** The turbine and bowl are supplied only as factory-balanced assemblies; match balance codes and dowel pin location and *do not interchange turbines and bowls*.
7. Examine spindle journals for damage or excessive wear. Replace base assembly (complete with spindle) if diameter is less than 0.590-in. (14.98 mm) top or 0.852-in. (21.63 mm) bottom. The spindle is pressed into the centrifuge base and aligned at the factory, and cannot be properly serviced in the field.
8. If the Level Control Base is used, check the control mechanism by using a thin wire with a hook formed on one end to engage the float arm on the bracket side. Raise the float. Air should flow into the control mechanism. Air flow should stop when the float is lowered. If the air control is defective, it must be repaired using Part 71603 (air cartridge assembly) or Kit 71609 (float assembly kit), following the instructions in the kits.
9. **Install the centrifuge turbine assembly on spindle, being careful of the bushings. Be sure it rotates freely.**
10. Clean and inspect cover, paying special attention to the cover nut assembly. The seal should be replaced if it shows signs of leaking. **Note:** To disassemble, remove the roll pin and the collar from the *top*, and withdraw the nut from the *bottom*.
11. Examine the base-to-cover seal and replace if damaged. The seal is Viton and can be reused several times.
12. Replace the cover assembly and tighten the cover nut securely *by hand pressure only*. Make sure that the cover seats on the base assembly evenly all around so that the cover seal is properly compressed. Replace the cover-to-base clamp and tighten the clamp nut securely by hand. Check all centrifuge and Level Control Base mounting bolts for proper tightness.
13. Close safety drain cock on the Level Control Base. Open air supply and oil supply to centrifuge. With engine running, check all connections and joints for leaks. Repeat assembly if vibration is excessive.

Note: All centrifuge turbines are correctly balanced before leaving the factory. An out-of-balance condition can occur as a result of uneven build-up of dirt in the bowl or as a result of excessive bearing or spindle journal wear. Depending on conditions, wear will eventually take place on the spindle and bearings, requiring replacement of the appropriate assemblies.

Sales and Service

SPINNER II[®]
PRODUCTS



T. F. HUDGINS
INCORPORATED

Oil Conditioning Systems NZ Ltd
PO Box 132-007 Sylvia Park, Auckland 1644
16 Aranui Rd (Apex Duo) Mt Wellington
Auckland 1060 Ph: (09) 570 2944
Fax: (09) 570 2942 Mob: 0274 485 942
Email: info@oilconditioningsystems.co.nz
Web: www.oilconditioningsystems.co.nz



Made in England by Mann+Hummel (UK) Ltd. Patented worldwide.
©Viton is a registered trademark of E.I. DuPont de Nemours & Co., Inc.
©Spinner II is a registered trademark of T.F. Hudgins, Incorporated.
©2002 T.F. Hudgins, Incorporated. All rights reserved.
Litho in U.S.A. Bulletin 71578/8-02