

SPINNER II®

OIL CLEANING CENTRIFUGE

Oil Conditioning Systems NZ Ltd

PO Box 132-007 Sylvia Park, Auckland 1644

16 Aranui Rd (Apex Duo) Mt Wellington

Auckland 1060 Ph: (09) 570 2944

Fax: (09) 570 2942 Mob: 0274 485 942

Email: info@oilconditioningsystems.co.nz

Web: www.oilconditioningsystems.co.nz



Model 400 HD 8 gpm at 40 psig
4,000 cc Dirt Capacity

Installation Instructions

Parts List

Service Instructions



Oil Supply to Centrifuge

Oil supply should, in general, be taken from the highest pressure, hottest source available on the dirty side of the full-flow oil filter. A 3/4-in. pipe or #12 hose supply line should be used with a full-opening ball valve installed at the centrifuge oil inlet so that the unit can be isolated for service without shutting down the engine. Preferred pressure is 60 to 80 psig but the Spinner II centrifuge will operate efficiently at 37 to 90 psig. Below 37 psig, an internal idle cut-out valve closes to prevent low oil pressure during low-speed operation.

Clean Oil Return to Sump

Level Control Base (LCB) — Preferred

The air-operated control in the Part No. 71602 LCB permits the Spinner II centrifuge to be installed on a base plate or deck in any convenient location near the engine, above or below the sump oil level. The clean oil drain line to the sump should be 1/2-in. diameter minimum *unrestricted* hose or pipe to a 1/2-in. connection located above oil level if possible — alternate oil-fill openings or drilled-and-tapped holes in crankcase doors are possibilities. Below-oil-level return drain requires that a 1/2-in. low opening pressure check valve be located at the LCB oil discharge to prevent back-flow when the centrifuge is being serviced. Only check valves are permitted in the drain line — **shut-off valves must never be used.**

Control Air Supply. The control in the LCB maintains the proper oil level for maximum centrifuge speed and efficiency. Compressed air to operate the LCB may be obtained from any 2 to 125 psi unregulated air source, as .15 SCFM is minimal. Any inlet pressure exceeding 125 psi must be regulated using P/N 71050. This regulator should be installed as shown, with a 1/4-in. air line connected to it using liquid sealant on threaded connections. In the absence of compressed air, it may be possible to use bleed air from the engine turbocharger or air from a positive displacement scavenging blower. This requires modifying the LCB for low-pressure operation. Remove regulator P/N 71050 and connect air supply directly into cartridge P/N 71603. This revised P/N 71603 is marked with wide band on hex. Use of 71246 Pre-Filter is recommended.

Assemble Spinner II unit with Part No. 70916 Seal to Level Control Base. Install Regulator.

Gravity Drain — Optional

For gravity drain without the Level Control Base, the Spinner II centrifuge must be close-coupled to the sump with an unrestricted 2.75" minimum drain returning above the normal sump oil level. The drain line must be sloped downward from the centrifuge outlet and be free of sharp bends or traps. On many engines, a crankcase door can be modified to provide a suitable drain opening as well as sturdy mechanical support. Be sure the sump side of the drain opening is clear and that the drain oil does not impinge on moving parts of the engine.

Mechanical Considerations

Spinner II centrifuges are high-speed devices and should be securely mounted to prevent excessive vibration. Operation up to 15 degrees from vertical is permitted.

Detailed Information Available

For optimum performance of your centrifuge, specific installation drawings for almost any engine can be requested from your distributor.

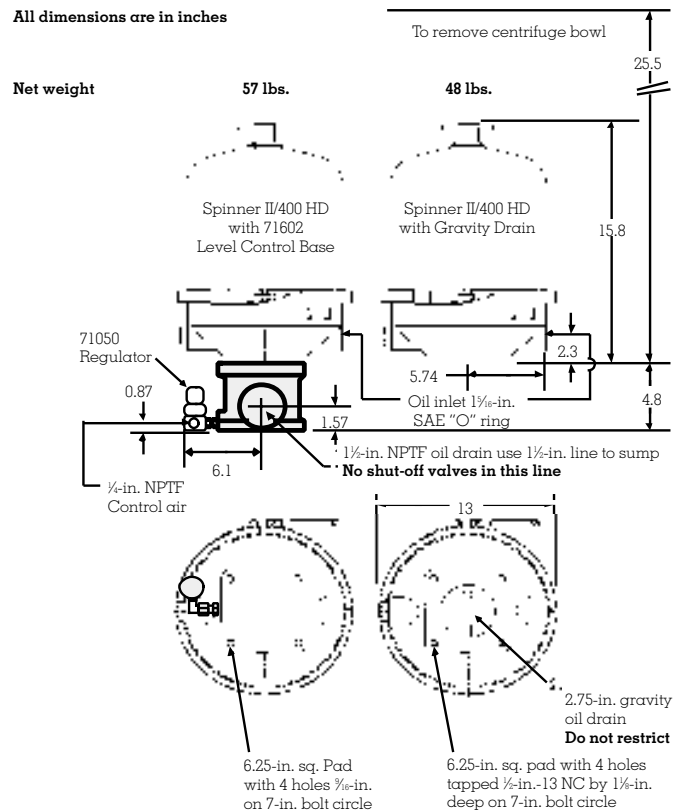

Spinner II Model 400 HD SAE 30 oil at 165°F/75°C

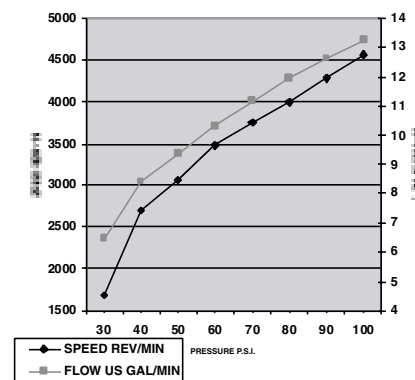

Model 400 HD Parts List

Only items shown with part numbers are available.
Bold denotes assembly

Cover assembly (k) 72953

Rotor assembly (b) 72948

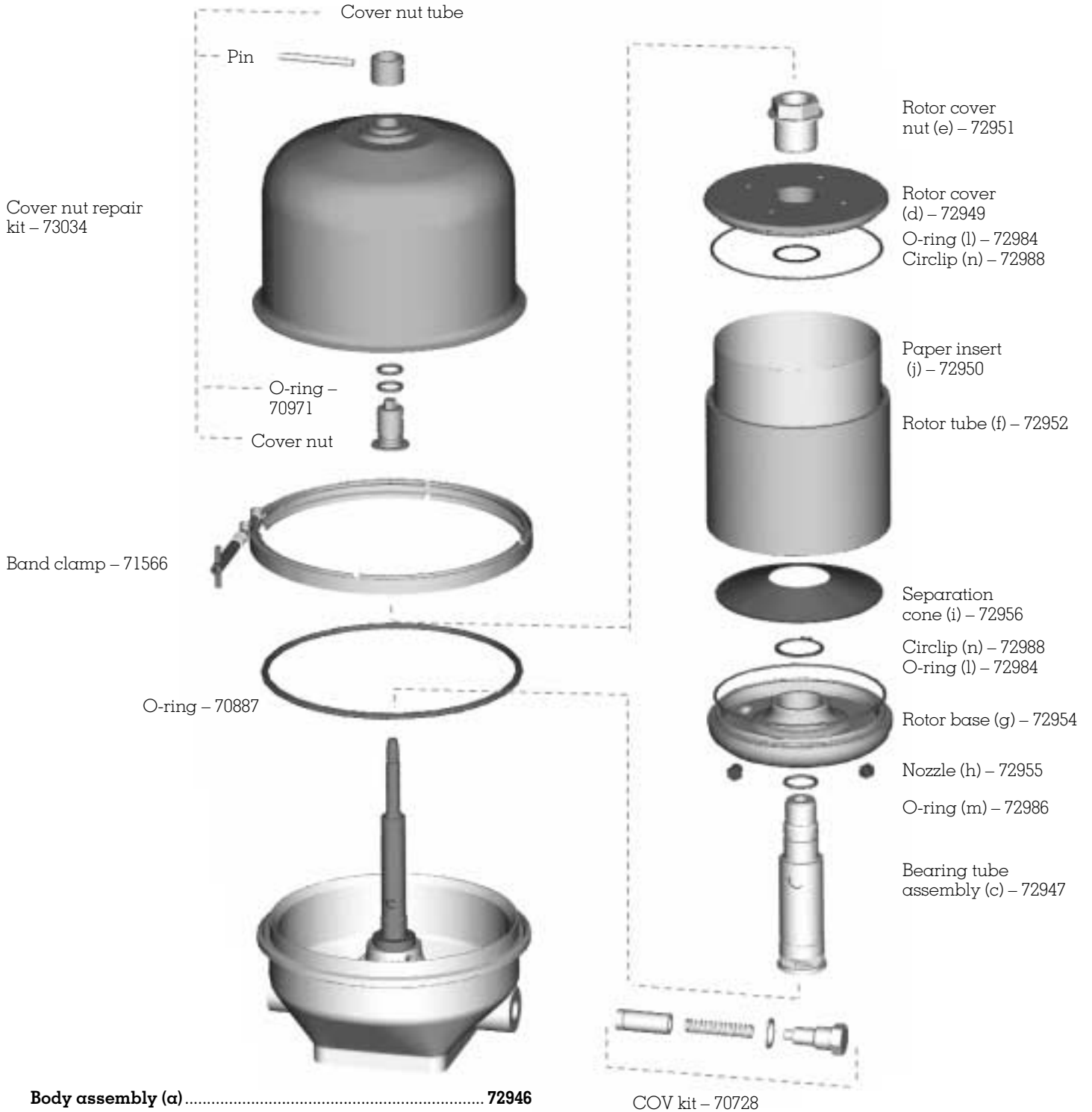

The Spinner II Model 400 HD Oil Cleaning Centrifuge should be cleaned at regular intervals ensuring that the thickness of the dirt deposit inside the rotor does not exceed approximately 1/4 in. (45 mm). This operation is normally carried out after a specified period of operational use and may be combined with other maintenance procedures.

Maintenance Procedure

1. Stop the flow of oil to the centrifuge by closing any installed inlet valves, or stopping the engine. Ensure the centrifuge has come to a complete stop before proceeding.
2. Remove the band clamp, unscrew the cover nut, and remove the centrifuge cover assembly.
Warning: Hot oil may exceed 100°F. Contacting centrifuge parts or oil may cause severe bodily damage. Allow unit and oil to cool or use protective gear.
3. Allow the oil to drain out of the rotor assembly. This may be assisted by raising the rotor on the spindle. Withdraw the rotor assembly vertically upwards from the spindle. The rotor should be removed and replaced on the spindle with care in order to ensure that the rotor bearings are not damaged.
4. With the rotor on the bench, hold the rotor using the rotor disassembly tool (P/N 72993). Unscrew the rotor cover nut. This will allow the rotor to split into 3 sections, the rotor cover, the rotor tube, and the rotor base. A flathead screwdriver may be used in the slots at either end of the rotor tube to aid disassembly.
5. Remove the separation cone from the rotor base (using a flathead screwdriver).
6. Remove all sludge deposits from the inside of the rotor components using a non-damaging metal or wood spatula. Clean the rotor components using a suitable cleaning fluid and discard the paper insert. Ensure that all rotor components, including the two nozzles located in the rotor base, are thoroughly cleaned and free from debris.
7. Examine the rotor assembly O-rings for damage, replace if necessary or at intervals of 2,500 hours.
8. Locate the separation cone into the rotor base and assemble the rotor tube onto the rotor base.
9. Fit new paper insert (P/N 72950) into the rotor tube.
10. Complete the reassembly of the rotor by replacing the rotor cover on to the bearing tube attached to the rotor base and tighten the rotor cover nut to a torque of 26 to 33 ft.-lbs. (35 to 45 Nm).
11. Examine the centrifuge body and spindle for signs of damage or wear and replace body assembly (P/N 72946) if necessary. **Do not try to repair.**
12. Replace rotor on spindle and check that the rotor spins freely.
13. Examine the centrifuge body O-rings for damage, change if necessary or at intervals of 2,500 hours.
14. Replace the centrifuge cover and tighten cover nut.
15. Replace the band clamp. **The band clamp must be securely fitted during operation of the centrifuge.**
16. With the centrifuge running, check all joints for leaks. Replace any worn components or leaking seals.

NOTE: If level control base is used: Check control mechanism by using a thin wire with a hook formed on one end to engage the float arm on the bracket side. Raise the float. Air should flow into the mechanism. Air flow should stop when float is lowered. If air control is defective, it must be repaired using Part No. 71603 (air valve cartridge kit), or Part No. 71609 (float assembly kit).

Important Notes

The Spinner II Oil Cleaning Centrifuge is designed to provide extended service without the need to replace major components. However, after extended periods of operation wear and damage to the centrifuge spindle and rotor assembly may become evident. For this reason it is recommended that the centrifuge spindle is checked for wear and rigidity. Replace the centrifuge body assembly (P/N 72946) if necessary. Also visually inspect the rotor assembly bearings for damage and wear during the cleaning process. If excessive wear or bearing play is evident (greater than .010 in. (0.25 mm) clearance on either journal bearing), the bearing tube assembly (P/N 72947) and/or the centrifuge body assembly (P/N 72946) should be replaced. Additionally, the air cartridge used in the level control base should also be considered a wear part, and needs to be inspected at each interval, and replaced if necessary.

The Model 400 HD centrifuge assembly is fitted with a Cut-Off Valve (COV) that is located in the filter body. The COV is designed to protect the engine by stopping the supply of lube oil to the centrifuge at start-up and during periods when the oil pressure is below the COV rating. This item is intended to provide maintenance free operation for extended periods and should only be disassembled and inspected for damage if a problem becomes evident.

Maintenance Action

Every Oil Drain Interval

- Clean rotor assembly/replace paper insert (P/N 72950).
- Inspect centrifuge body O-ring and rotor body O-rings. Replace every 2,500 hours or if damaged.
- Check cover nut O-rings for leaks, replace every 2,500 hours or if necessary.
- Inspect rotor bearings for damage and wear. Replace bearing tube assembly if necessary (P/N 72947).
- Inspect spindle for wear and looseness and replace centrifuge body assembly (P/N 72946) if necessary.
- Inspect air cartridge used in the Level Control Base (LCB). Replace if necessary.

NOTE: This should be used as a guide only. Maintenance intervals differ with engine type and operational environment.

Sales and Service

SPINNER II®

PRODUCTS



T. F. HUDGINS
INCORPORATED

Oil Conditioning Systems NZ Ltd
PO Box 132-007 Sylvia Park, Auckland 1644
16 Aranui Rd (Apex Duo) Mt Wellington
Auckland 1060 Ph: (09) 570 2944
Fax: (09) 570 2942 Mob: 0274 485 942
Email: info@oilconditioningsystems.co.nz
Web: www.oilconditioningsystems.co.nz

