

Spinner II centrifuges are available for virtually any industrial fluid-cleaning application

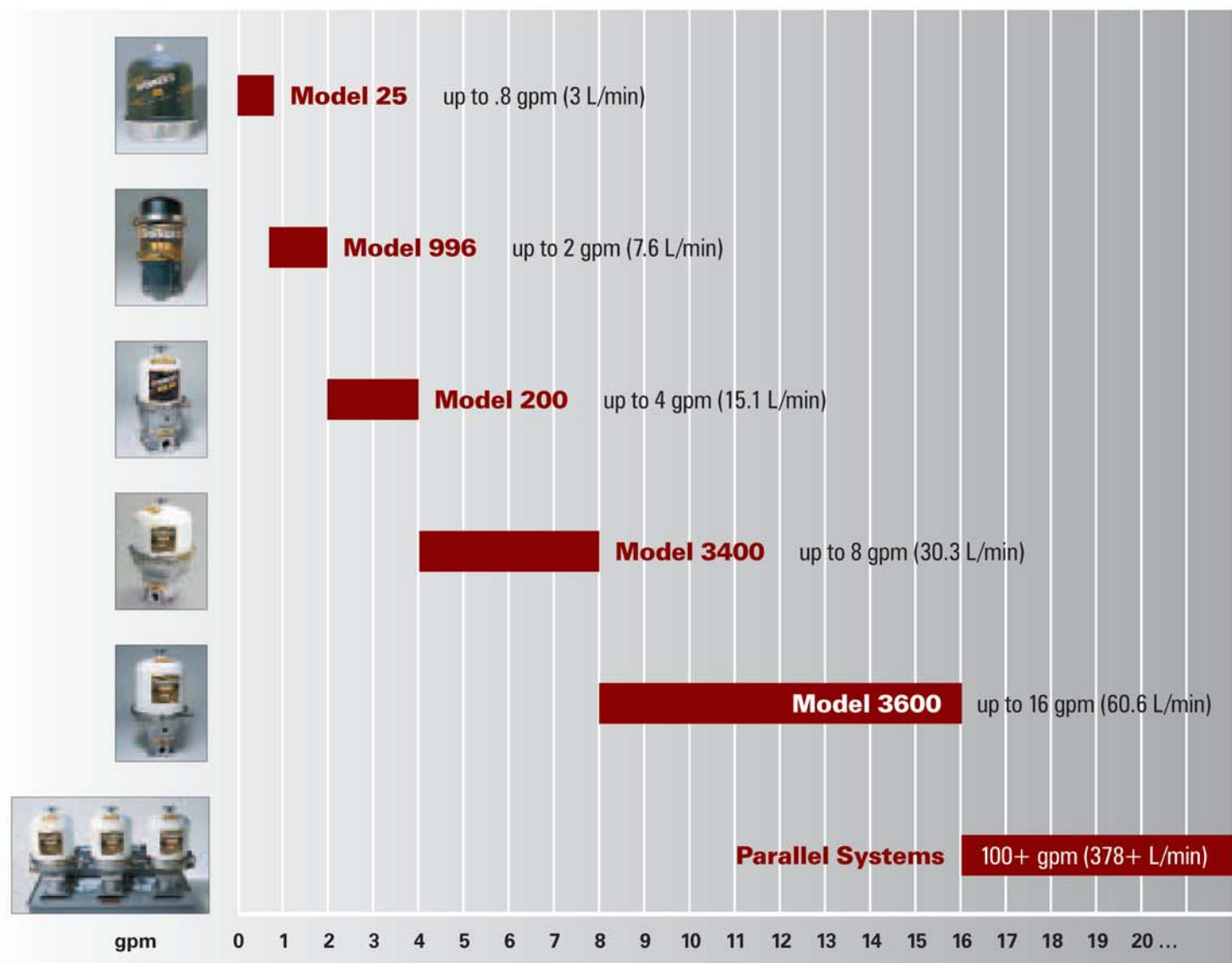

Proven World-Class Performance

For over 30 years, Spinner II centrifuges have provided exceptional fluid-cleaning performance, with more than 650,000 units in operation worldwide. They have been installed as OEM first fit for more than 40 engine manufacturers — including Caterpillar, Waukesha, White Superior, EMD, Alco, General Electric, Detroit Diesel, Clark Bros., Ingersoll-Rand, Cooper-Bessemer, Cummins, MTU and many others.

Spinner II centrifuges can be specified on new equipment or retrofitted to existing machinery. Every unit is backed by responsive engineering and technical support.

To find out how Spinner II Xtreme Cleaning makes your operation more productive and cost-effective, contact Spinner II Products or your local representative.

SPINNER II[®]
PRODUCTS



Oil Conditioning Systems NZ Ltd
 PO Box 132-007 Sylvia Park, Auckland 1644
 16 Aranui Rd (Apex Duo) Mt Wellington
 Auckland 1060 Ph: (09) 570 2944
 Fax: (09) 570 2942 Mob: 0274 485 942
 Email: info@oilconditioningsystems.co.nz
 Web: www.oilconditioningsystems.co.nz



©Spinner II and Xtreme Cleaning are marks of T.F. Hudgins, Incorporated.
 ©2005 T.F. Hudgins, Incorporated. All rights reserved.
 Litho in U.S.A. Bulletin No. 70 ____/____M/0105

Spinner II[®] Centrifuges

Xtreme Cleaning[™]
 for Industrial Lubricants and Fluids



Reduce Wear

Cut Operating Costs

Eliminate Waste

SPINNER II[®]
PRODUCTS

Lubricating fluids are the lifeblood of mechanical processes. Maintain enhanced fluid cleanliness, and your machines will run longer, last longer and cost less to operate. That's the essence of Xtreme Cleaning, the performance you get only with Spinner II centrifuges.

Spinner II centrifuges are highly efficient, self-contained, fluid-cleaning units for bypass and off-line filtration of engine lubricants, gear oils, machining fluids, hydraulic oils, quench oils and other industrial fluids.

Using the power of centrifugal force, they remove both large contaminants and ultra-fine particles as small as one-tenth of a micron. In a broad range of applications, Spinner II centrifuges are proven to reduce critical component wear up to 50%*. They also meet the challenge of new, low-emissions engines by providing the efficiency to control increased soot loads.

Enhanced Efficiency

The latest generation of Spinner II centrifuges feature a patented rotor design with enhanced flow dynamics. Biased flow channels in the rotor cover act as "centrifugal pumps," forcing fluid away from the axis to maximize liquid/solid separation.



Patented flow channels

Xtreme Cleaning Cuts Your Operating Costs

Protects Machinery

- Reduces wear up to 50%
- Increases component life
- Helps reduce frequency of maintenance and repair

Extends Operating Intervals

- Keeps fluids and additives effective longer
- Prolongs full-flow filter life
- Centrifuge requires minimal service

Eliminates Waste

- Permanent, cleanable and reusable
- No media or filter elements to replace
- Protects the environment by reducing disposable waste

How Spinner II Centrifuges Operate

Spinner II centrifuges are typically self-powered (pump-assisted units are also available). They create fluid pressure sufficient to generate centrifugal force 2,000 times greater than gravity. This force extracts solid contaminants from the fluid stream and deposits them in the cleanable rotor as a dense, solid cake.

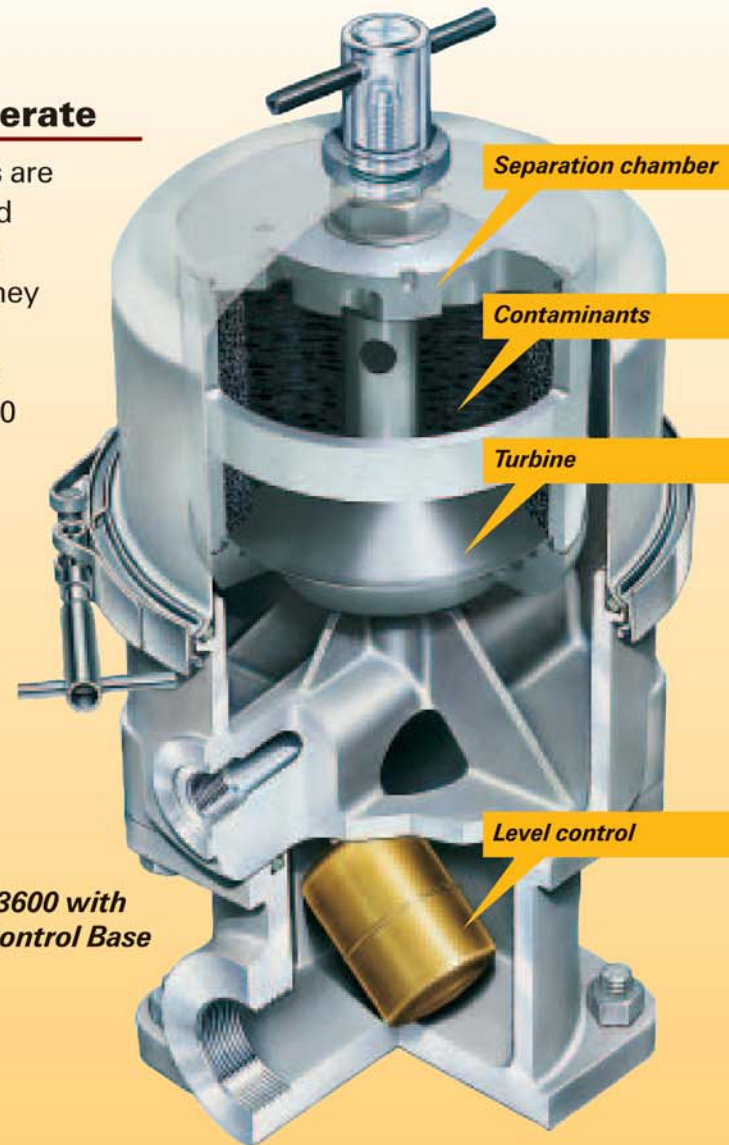

Model 3600 with Level Control Base

Flow Path

Fluid passes through a spinning rotor where centrifugal force 2,000 times greater than gravity separates contaminants from the fluid.

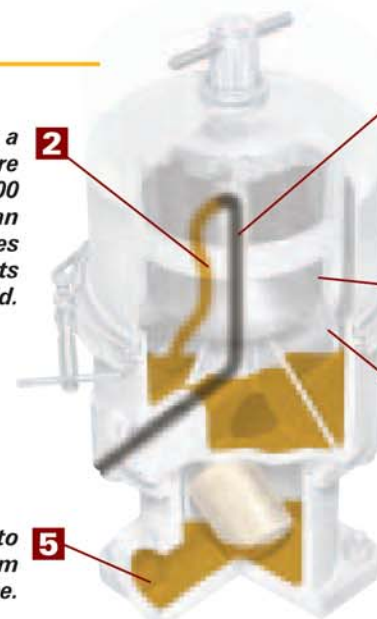

1 Dirty fluid flows up through a hollow spindle into a separation chamber.

3 Contaminants accumulate on the rotor surface as a solid cake.

4 Clean fluid exits from tangentially-opposed nozzles, powering the centrifuge up to 7,000 rpm.

5 Clean fluid returns to the sump/reservoir from the level control base.

Operational Advantages

- Maintains constant cleaning efficiency
- No channeling, plugging or fouling
- Simple, convenient installation
- No replacement elements
- Contaminant access for engine troubleshooting
- Enhances long-term preventive maintenance



Visible proof. Clean (top) and dirty (inset) rotors from a Model 3600 centrifuge, show actual contaminants removed in one interval.



Spinner II Grid Switch' Wear Detectors. These optional devices can be installed in-line to monitor the presence of metal particles and provide advanced warning of excessive wear conditions.

Low Maintenance, Easy to Service

Maintenance intervals for Spinner II centrifuges vary according to your specific operating conditions and service hours. However, all models are designed with large capacities to allow extended hours of service.

For routine maintenance, simply remove the rotor cover and empty the dry, compacted contaminants. There are no expensive filter elements to replace, and nothing to drain, crush or haul away.



Spinner II CS Systems. Combine a Spinner II centrifuge with a full-flow, stainless steel, cleanable screen to completely eliminate the need for disposable filters. These systems have been designed to flow up to 1,200 gpm (4,542.5 L/min).

Oil Conditioning Systems NZ Ltd
 PO Box 132-007 Sylvia Park, Auckland 1644
 16 Aranui Rd (Apex Duo) Mt Wellington
 Auckland 1060 Ph: (09) 570 2944
 Fax: (09) 570 2942 Mob: 0274 485 942
 Email: info@oilconditioningsystems.co.nz
 Web: www.oilconditioningsystems.co.nz



*Test reports available